

Precision Calibrator



FEATURES

- Portable, on-site calibration and servicing—accurate to 0.02% of selected range
- Eight selectable ranges: 0, 0.5, 1.0, 1.5, 2.0, 2.5, 3.0, and 3.5mV/V
- Three bridge impedance selections: 350, 700, or 1000 ohms
- Calibrate any strain gage based transducer instrument, transmitter, or indicator
- Rugged, impact resistant aluminum case

DESCRIPTION

The Model 325 precision calibrator supplies high accuracy millivolt-per-volt level signals for testing, calibrating, and troubleshooting process weigh system instrumentation. Precise output reference selections from 0 to 3.5mV/V are achieved by using a metal film resistor network, discrete wire wound resistors, and a 2-pole, 8-position rotary switch. Input and output impedance values of 350, 700, and 1000 ohms are selectable to simulate all typical strain gage transducers. Four permanent binding posts, integral to the rugged aluminum case, provide connection points for the instrument or transmitter.

A built-in vernier adjustment provides a mV/V output signal from 0 to 106% of the selected range. Full range simulation tests setpoint cutoffs, auto-tare, auto-zero, overload, and other crucial instrument functions without loading the system.

The Model 325 unit substitutes for single or multiple system transducers. Lightweight construction, compact size, and superior accuracy make the Model 325 calibrator an excellent choice for calibrating, spot-checking, or trouble shooting weigh systems in any environment.

APPLICATIONS

- Testing, calibrating, and troubleshooting process weigh system instrumentation

SPECIFICATIONS

PERFORMANCE

Output Accuracy	0.02% of selected range
Accuracy Stability	less than 0.01% in 24 hours
(0.5 and 1mV/V steps)	less than 0.02% in 1 year
Zero Stability	less than 3 μ V
Span TC	\pm 10ppm/ $^{\circ}$ C
Input Impedance	adjustable to \pm 0.05%
(Excit.)	
Output Impedance	adjustable to \pm 0.08%
(Signal)	
Output Ranges	8 steps: 0, 0.5, 1.0, 1.5, 2.0, 2.5, 3.0, and 3.5mV/V

Input Voltage Level	25V do maximum
Operating Temperature	32 to 120 $^{\circ}$ F (0 to 50 $^{\circ}$ C)
Range	
Vernier Range	up to 106% of selected step
Impedance Adjustment	350, 700, or 1000 ohms

MECHANICAL

Dimensions (inches)	6 x 3.2 x 1.8 inches (LxWxH)
Unit Weight	15.7 ounces

DIMENSIONS in inches

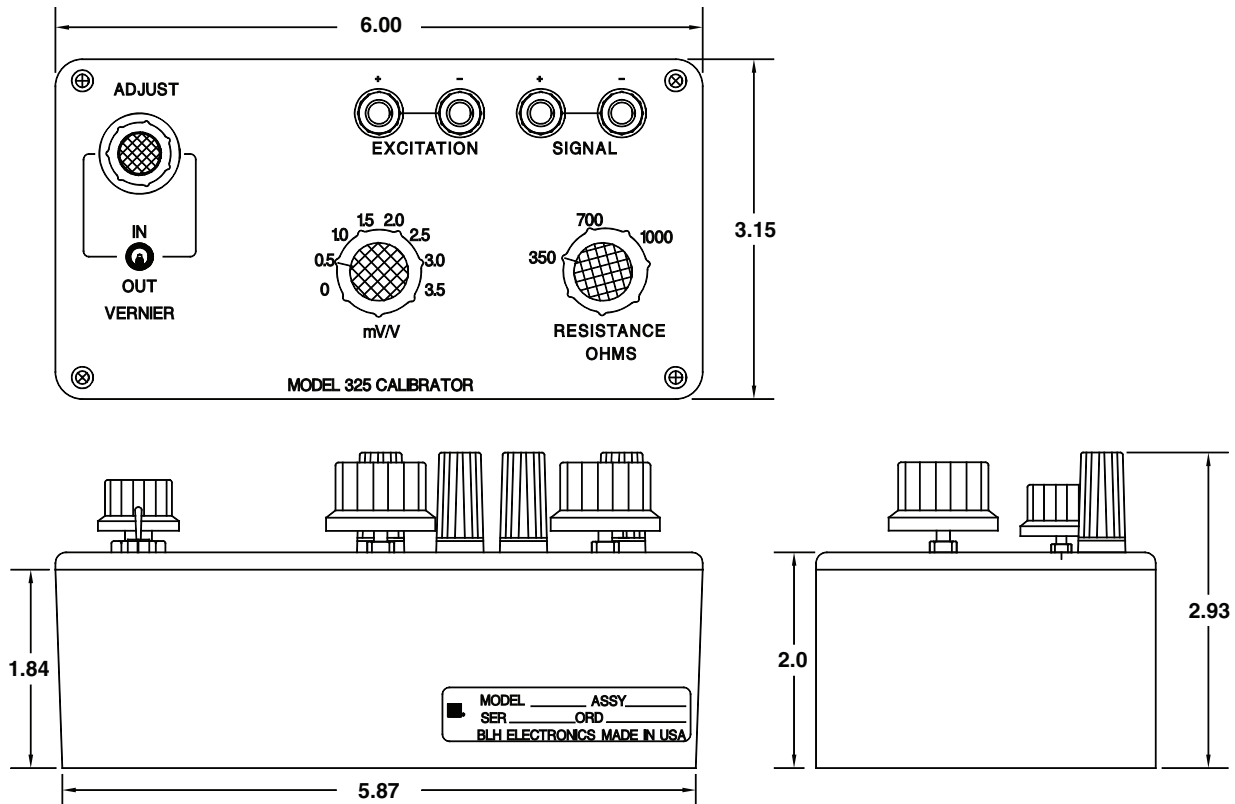

Disclaimer

All product specifications and data are subject to change without notice.

Vishay Precision Group, Inc., its affiliates, agents, and employees, and all persons acting on its or their behalf (collectively, "Vishay Precision Group"), disclaim any and all liability for any errors, inaccuracies or incompleteness contained herein or in any other disclosure relating to any product.

Vishay Precision Group disclaims any and all liability arising out of the use or application of any product described herein or of any information provided herein to the maximum extent permitted by law. The product specifications do not expand or otherwise modify Vishay Precision Group's terms and conditions of purchase, including but not limited to the warranty expressed therein, which apply to these products.

No license, express or implied, by estoppel or otherwise, to any intellectual property rights is granted by this document or by any conduct of Vishay Precision Group.

The products shown herein are not designed for use in medical, life-saving, or life-sustaining applications unless otherwise expressly indicated. Customers using or selling Vishay Precision Group products not expressly indicated for use in such applications do so entirely at their own risk and agree to fully indemnify Vishay Precision Group for any damages arising or resulting from such use or sale. Please contact authorized Vishay Precision Group personnel to obtain written terms and conditions regarding products designed for such applications.

Product names and markings noted herein may be trademarks of their respective owners.